

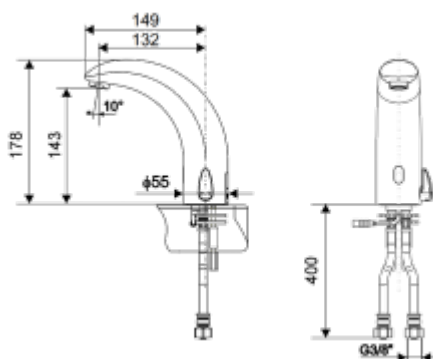

## Electronic photocell battery with mixer 3101

- Dirt filter and reverse valve at a connecting hose inlet
- Protection against flooding
- Easy access for a battery replacement
- Anti-vandalism construction
- Infrared sensor with activation on presence detection
- External power supply 230V AC/6V DC or CRP2 battery
- Sealed battery box for installation under basin
- Water and energy saving
- Comfortable operation
- High level of hygiene

Power	230V AC/6V DC/ CRP2 battery
Connector	2 x G3/8
Temperature	5-70°C
Design	Brass covered with chrome
Water time flow	6 l/min
Start	Infra-red sensor
Operating pressure	Min - 0,5 - max - 10 bar
Spout	With vandal-resistant aerator



Photocell sink battery with mixer. Equipped in hand mixer. Designed for public facilities and food processing facilities.